

156.405



OPEL Astra SportsTourer (With Rails) 5
 OPEL Zafira III 5

2010->2015
 2011 ->2018



Ne pas dépasser le poids total autorisé en charge (PTAC) sur le toit du véhicule.
 No debe sobrepasarse el peso total permitido sul techo del vehículo motorizado
 Non superare il peso complessivo ammesso sul tetto del veicolo
 Das zulässige Gesamtgewicht des Kraftfahrzeuges darf nicht überschritten werden

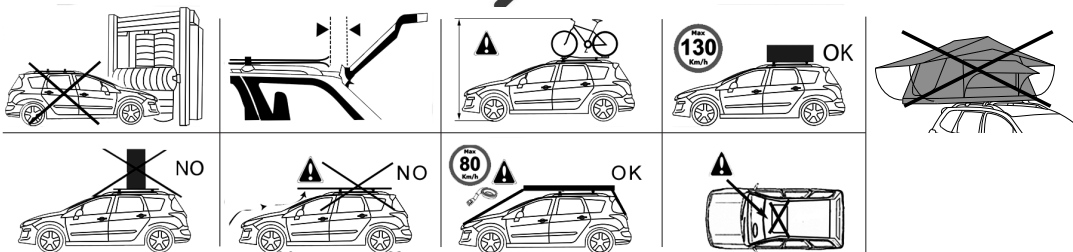

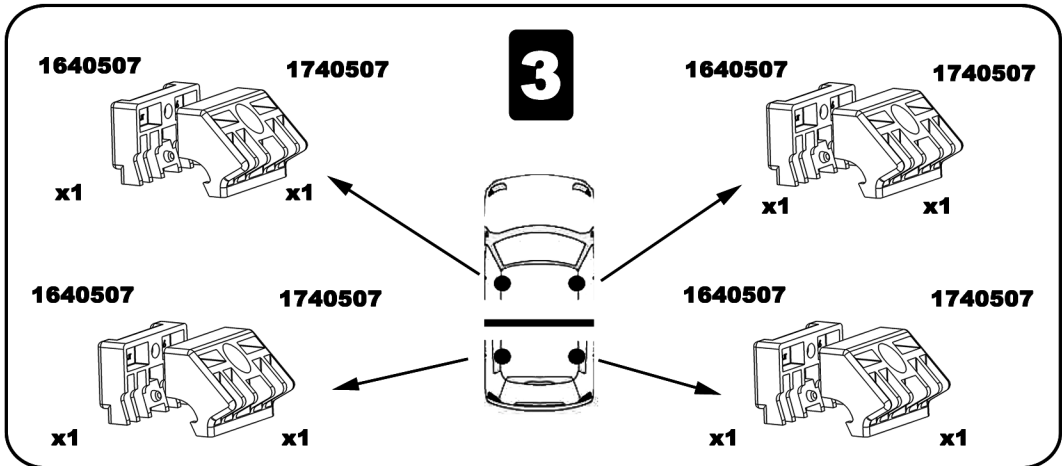
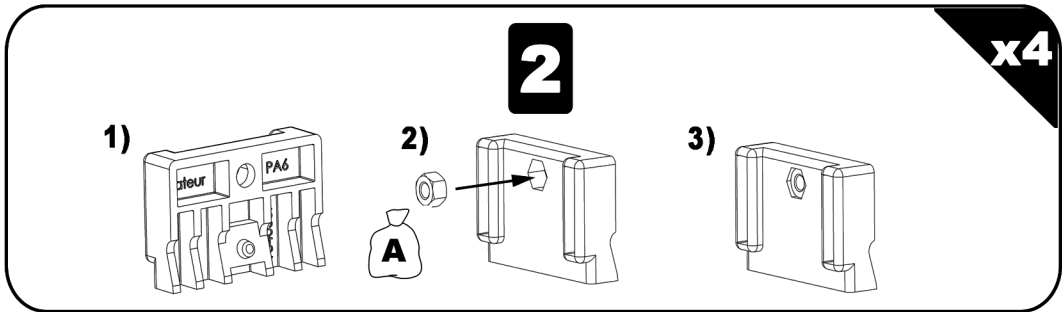
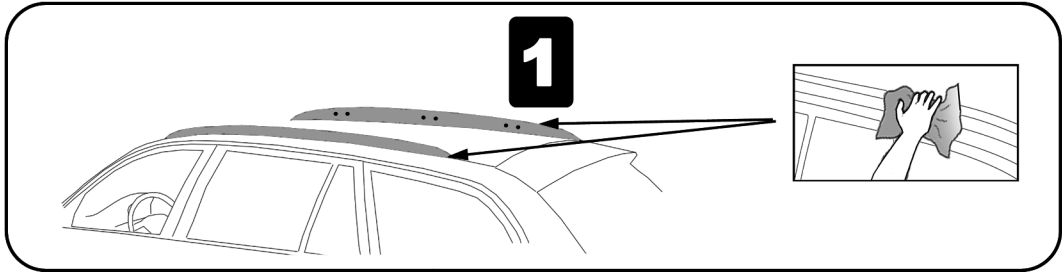
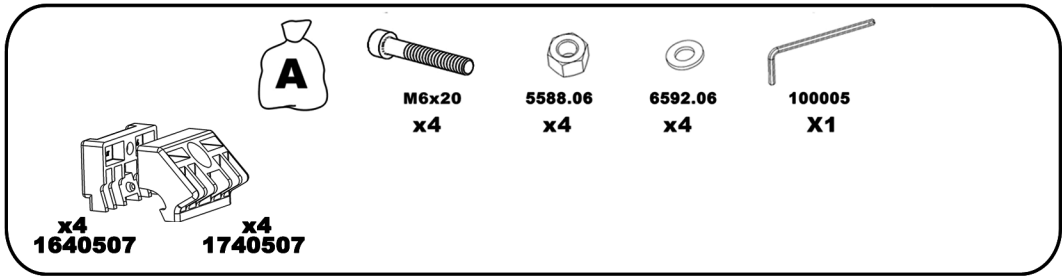

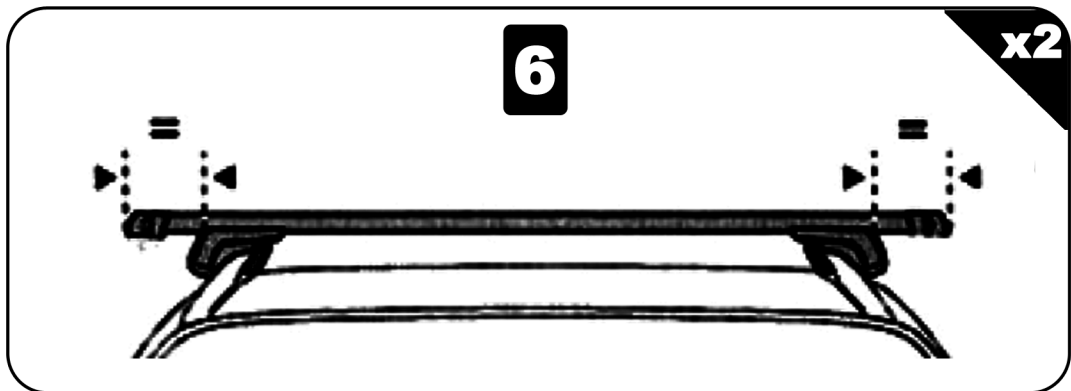
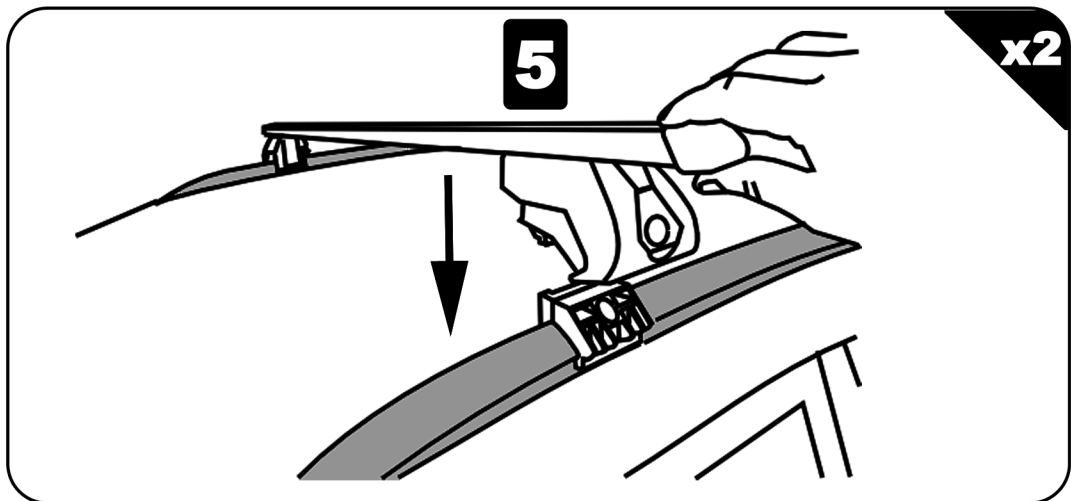
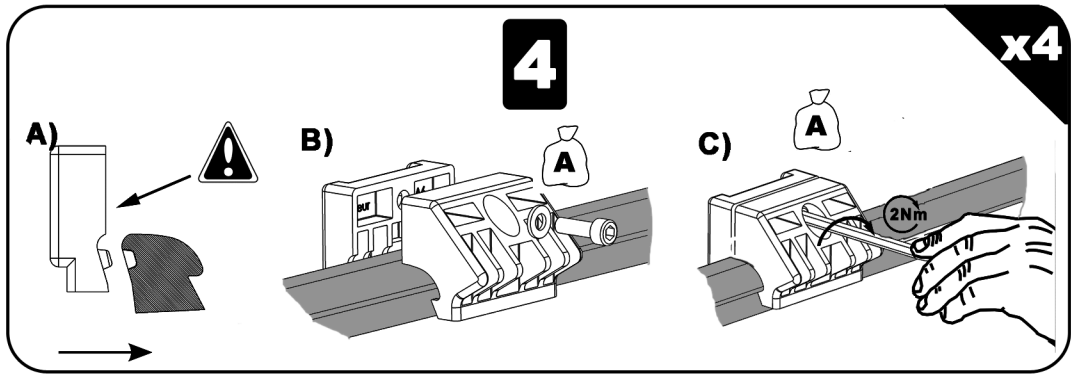

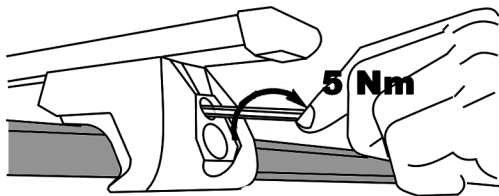
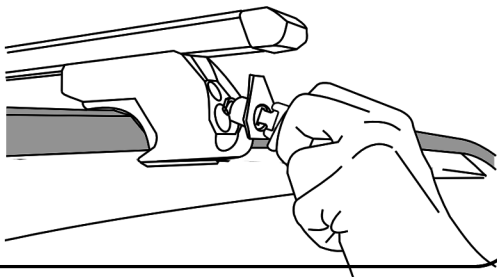
7**x4****8****x4**

FR: Charge maxi 75 kg ne pas dépasser la charge maximale admissible par le constructeur du véhicule.
IT: Carico massimo 75 kg non superare il carico massimo sul tetto indicato dal costruttore del veicolo.
SP: Capacidad máxima de carga 75 kg no exceda la maxima carga permitido por el fabricante del vehículo.
PT: Capacidade máxima de carga 75 kg não exceder a carga máxima permitida pelo fabricante do veículo.
EN: Maximum carrying capacity 75 kg do not exceed the maximum allowable load by the vehicle manufacturer.
DE: Zulässige höchstlast 75 kg überschreiten sie nicht die maximale belastung zulässige vom fahrzeughersteller.
NL: Maximaal toegestaan 75 kg neem niet meer de maximale belasting toegestane door de voertuigfabrikant.

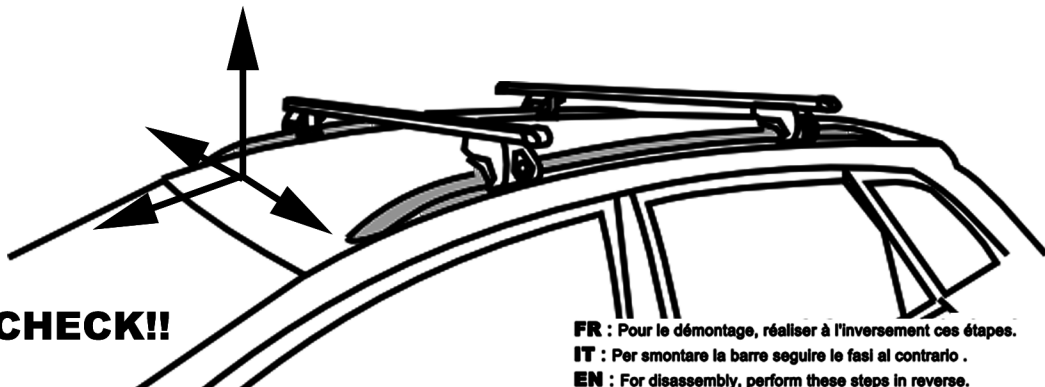
**CHECK!!**

FR : Pour le démontage, réaliser à l'inversement ces étapes.
IT : Per smontare la barre seguire le fasi al contrario .
EN : For disassembly, perform these steps in reverse.
ES : Para desmontar, siga estos pasos a la inversa.
PT : Para desmontar, execute estas etapas em ordem Inversa
NL : Uit elkaar te halen, voert u deze stappen in omgekeerde.
DE : Zu zerlegen, diese Schritte in umgekehrter